

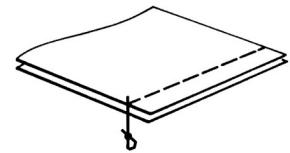

— *Finest Quality, from* **Union Special**[®]
INDUSTRIAL SEWING EQUIPMENT

56100 SERIES for Making Bags

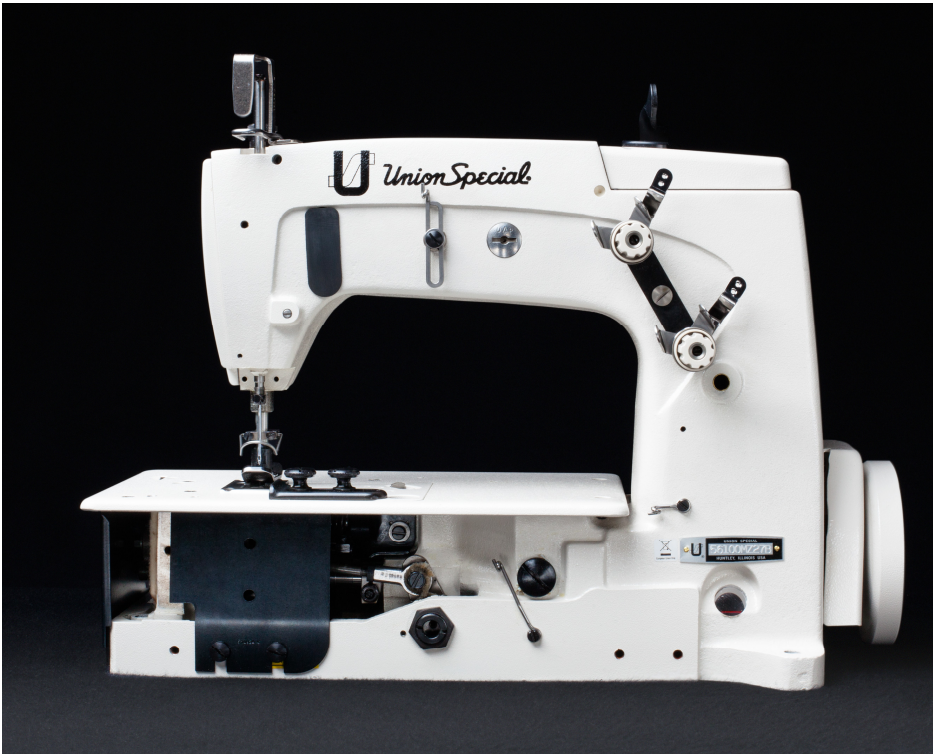

101 SSa-1

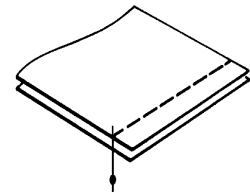

401 SSa-1

The 56100 series are rugged, long-lasting high duty-cycle machines for seaming bags made of paper, poly, cotton, burlap and laminated poly. High-performance parts include a new left end bearing, which allows the shaft to run smoother and cooler and new design looper thread take-up, which eliminates thread wrap-ups. This means no more downtime or repair labor due to a burned up bushing or thread wrapped around the take-up! Also included in these new machines is a new oil return pump to help with machine lubrication.

New Take Up

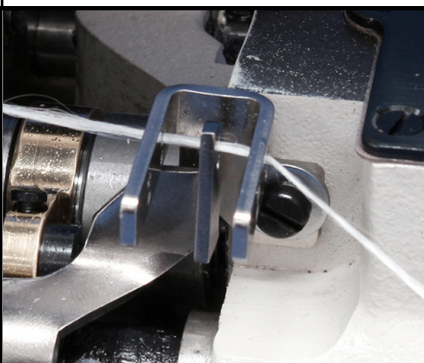

Eliminates thread wrap-ups

New Mainshaft Bearing

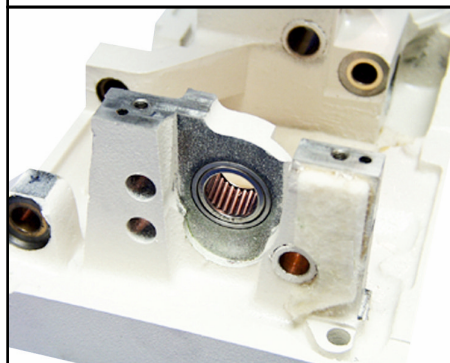

Smoother and cooler

New Oil Pump

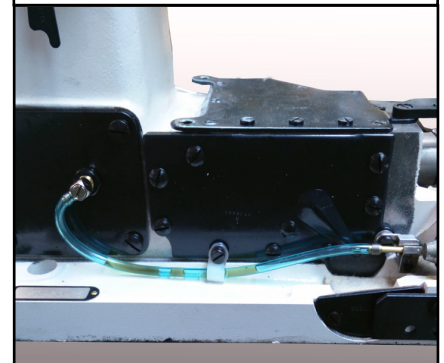

Better oil flow



Finest Quality, from

Union Special
INDUSTRIAL SEWING EQUIPMENT

56100 Specifications STYLE & APPLICATION	STITCH & SEAM	STITCH LENGTH	SEWING CAPACITY	MAXIMUM RPM *
56100MBT: for seaming bags made of cotton, light to medium weight burlap, paper, jute or woven poly.	401SSa-1	3.6-7.2mm 3.5-7SPI	up to 8mm 5/16"	6000
56100PBT: similar to 56100MBT, except with high needle throw and wider feed parts for seaming medium to extra-heavy weight bags.	401SSa-1	3.6-7.2mm 3.5-7SPI	up to 11mm 7/16"	5500
56100TBT: for hemming openings, or making double turned-in side and bottom seams on burlap, paper, jute, or woven poly bags. Also for sewing spouts on FIBCs. Turned up hemmer adjusts from 10 to 15mm, capacity from 2 to 4mm.	401EFb-1	3.6-7.2mm 3.5-7SPI	up to 8mm 5/16"	5500
56100MZ27BT: similar to 56100TBT, without hemmer.	401SSa-1	3.6-7.2mm 3.5-7SPI	up to 8mm 5/16"	5000
56100MZ34BTA: similar to 56100MZ27BT, except for use on automated equipment.	401SSa-1	3.6-8.5mm 3.0-7SPI	up to 8mm 5/16"	4800
56100SABTA: WITH TOP FEED , for seaming laminated poly bags with a 401 stitch where chaining is required (Non-tape applications) Fitted with full close plate.	401SSa-1	3.6-8.5mm 3.0-7SPI	up to 6mm 15/64"	4300
56100RBTA: WITH TOP FEED , for seaming heavy multi-wall paper and laminated poly bags. With single thread 101 stitch. Tape is required. Presser foot has filler cord guide and tape slot. Fitted with full close plate.	101SSa-1	3.6-8.5mm 3.0-7SPI	up to 6mm 15/64"	4300

Sewing Parts

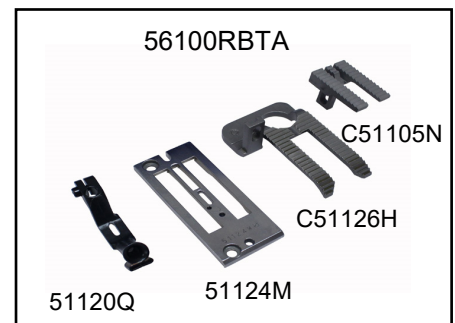
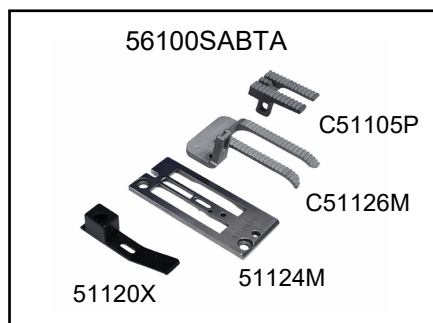
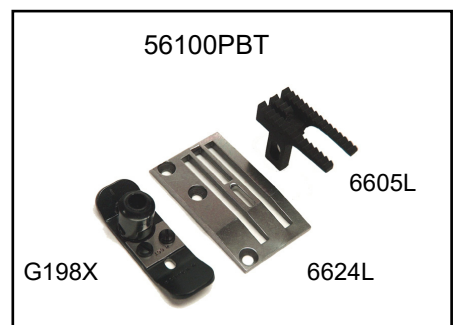
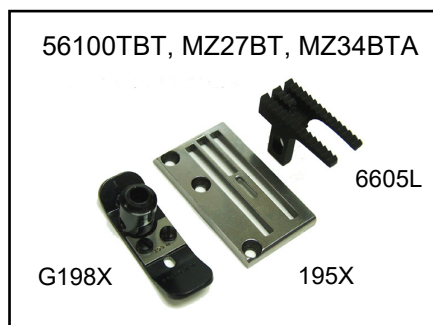
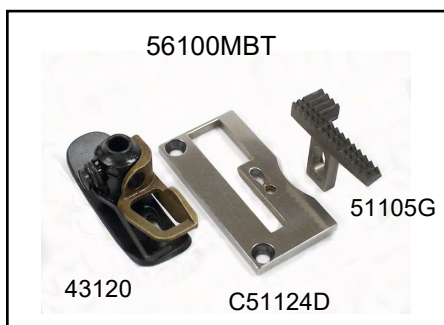

Subject to change without notice © Union Special GmbH

Union Special LLC
One Union Special Plaza
Huntley, IL 60142, USA
Phone: 847/669 4500, Fax: 847/669 4239
www.unionspecial.com

Union Special GmbH
Raiffeisenstraße 3
71696 Möglingen, Germany
Tel: +49 (0)7141/247-0, Fax: +49 (0)7141/247-100
www.unionspecial-gmbh.com

05-17_en